

IP wireless fiber optic remote power



# KBC Transmission & Remote Power Products



[www.kbcnetworks.com](http://www.kbcnetworks.com)

Version 022018



## Transmission for a wide range of applications and markets

KBC industrial products are built to perform in non-conditioned environments, featuring wide operating temperatures and hardened casings.

### Applications

- CCTV & surveillance
- Security
- Intelligent Transport Systems (ITS)
- Telemetry & SCADA
- Industrial control
- Access control systems
- Remote video, voice & data transmission
- Building & site management

### Verticals

- Town & city center
- Transportation
- Critical National Infrastructure
- Petrochemical
- Power & utilities
- Government agency
- Military systems
- Counter-terror
- Homeland security
- Remote data
- Emergency services
- Commercial & retail
- Residential



# The KBC Networks Product Range



No matter how good your endpoint technology is, the way you get your signals from A to B will ultimately decide whether your system works the way you need it to. We design and deliver trusted and reliable transmission solutions to get your signals from A to B and C and beyond.



## IP

**ThruLink: Industrial VPN for encrypted and secure WAN transmission**

- Transmits IP signals over any type of WAN/LAN
- Embedded 4G/LTE version for streaming secure live video from vehicles
- Supports meshed networks; flexible & scalable
- Supports FIPS and encryption Blowfish, AES & Camellia up to 256 bit
- Auto-reconnects if the network connection fails, multiple failover.



**Media Converters: maximum flexibility provided through multiple options**

- 10/100/1000Mbps media converters, Single mode and multimode
- PoE & SFP options available
- Compact size, Industrial rating
- Mounting configurations include Wall, DIN Rail & 2U High Rack Chassis options

## eCopper™



**EoC/EoU – eCopper™ – a simple way to transmit Ethernet over Coax or UTP**

- 1,4,8 and 16 Channel models
- Transmit up to 1,200 Feet PoE+
- Transmit up to 2,600 Feet PoE
- Current protection
- POC Management



**Switches: Managed and Unmanaged, PoE, PoE+, PoE++, Daisy Chain & Ring Configuration**

- Feature Rich
- Reliable High Performance
- Rugged IP40 Design
- Easy to Configure
- Supports ERPS
- Wide range of industrial SFPs available



## Wireless

**WES3 & WES3 HTG Point to Point, Point to Multi-Point & Mesh topologies**

- WES3HTG – gigabit wireless 1.3 Gbps aggregate, 650 Mbps directional throughput
- WES3 – standard 99 Mbps throughput – versatile and easy setup
- Feature rich enhanced firmware
- 25 years of secure, reliable no-dig solutions
- Simple to use kit packaging



## Fiber Optic

**A full line of Digital Standard and ASFOM fiber optic products**

- Digital Standard – building blocks for point to point video, audio and data transmission
- ASFOM – Application Specific Fiber Optic Modules – custom configurable for the most demanding applications
- Wide range of industrial SFPs available



## Remote Power & Surveillance

**A full range of solar, wind and remote power solutions including UPS, power kits, power supplies and accessories**

- AL2/AL5 Off-Grid power
- UAL2/UAL5 Backup Power 24/7
- MSS Temporary Surveillance
- SPB Engineered Power

KBC transmission products are installed worldwide in security and surveillance; site management; intelligent transport networks and industrial control systems. Our products drive video, voice and data over wireless links, Ethernet and IP, mobile, 3G / 4G / LTE and fiber optic networks. With such a broad range of technologies, we can provide you with information and support to deliver the best solution for your application.

### Secure transmission over public networks

Encrypted transmission over the Internet, 3G/4G/LTE

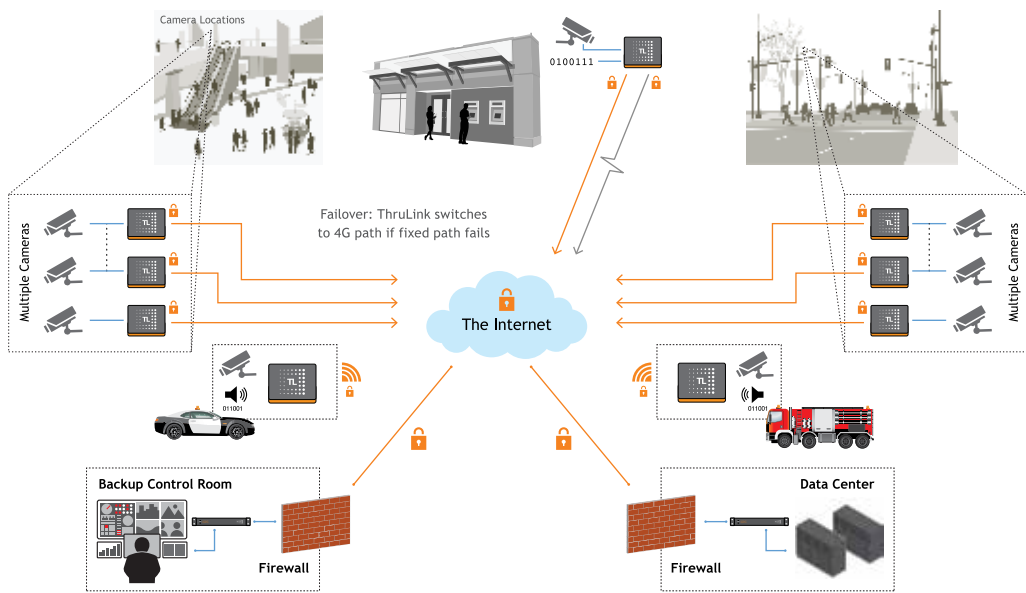

### Wireless transmission

Point-to-point, point-to-multipoint, mesh & 4G/LTE

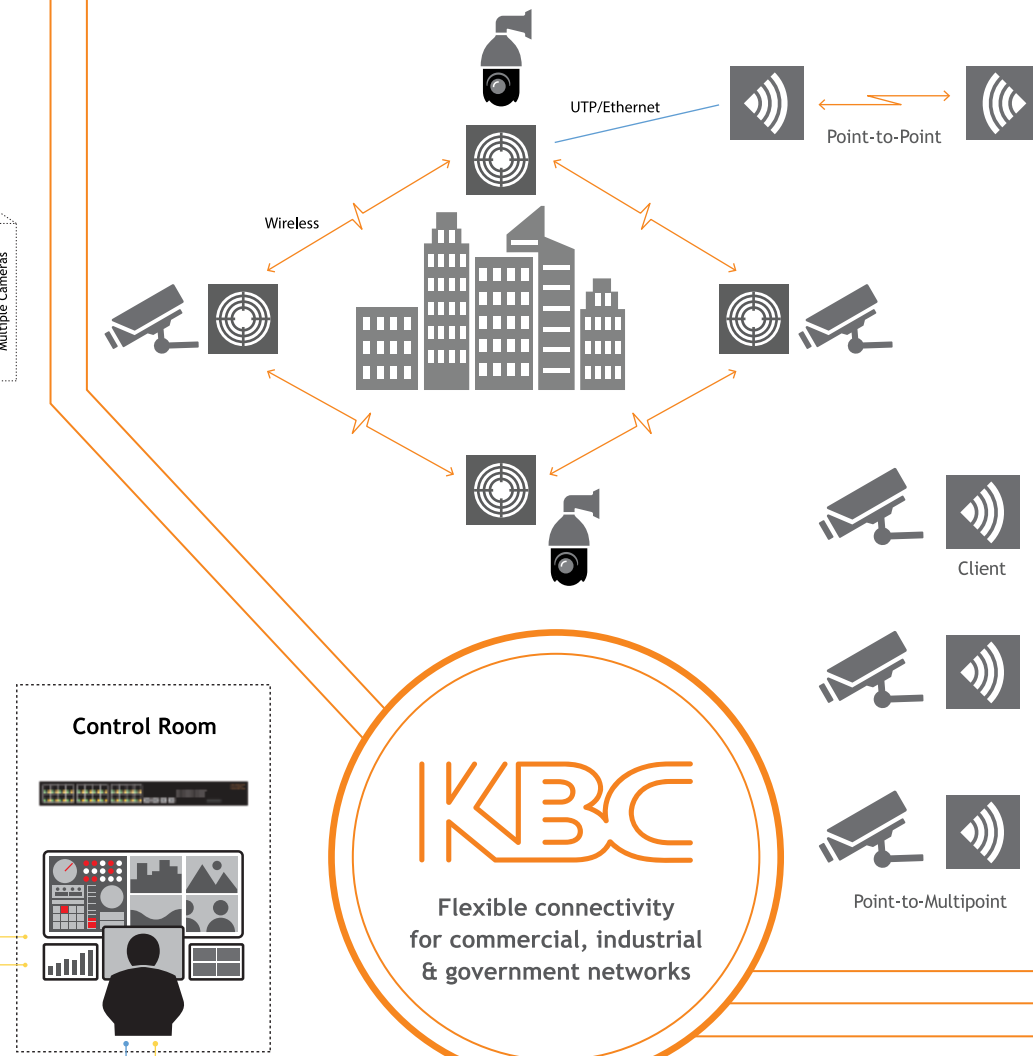

### Remote power solutions

Solar, wind, UPS & PoE power kits

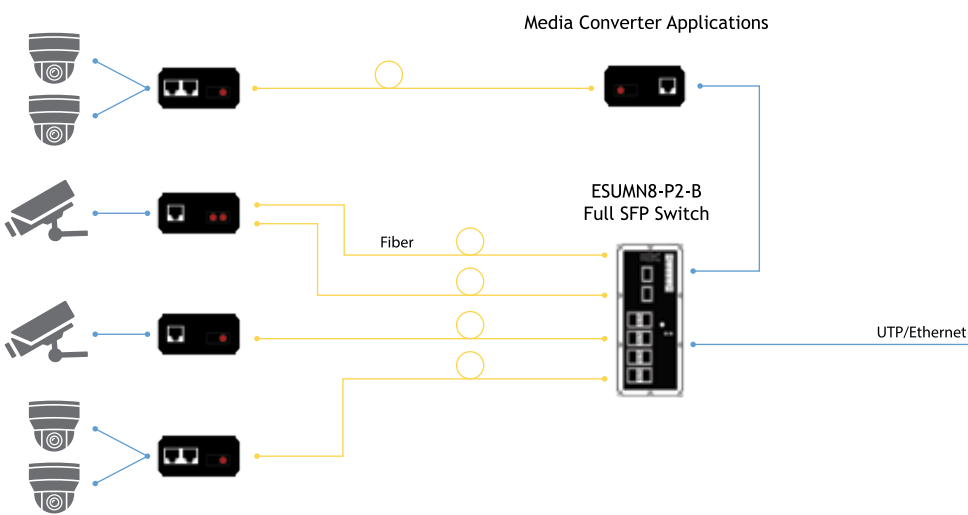
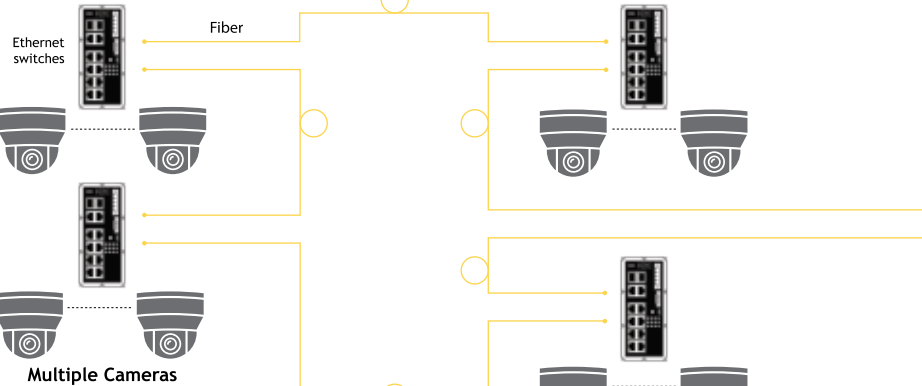
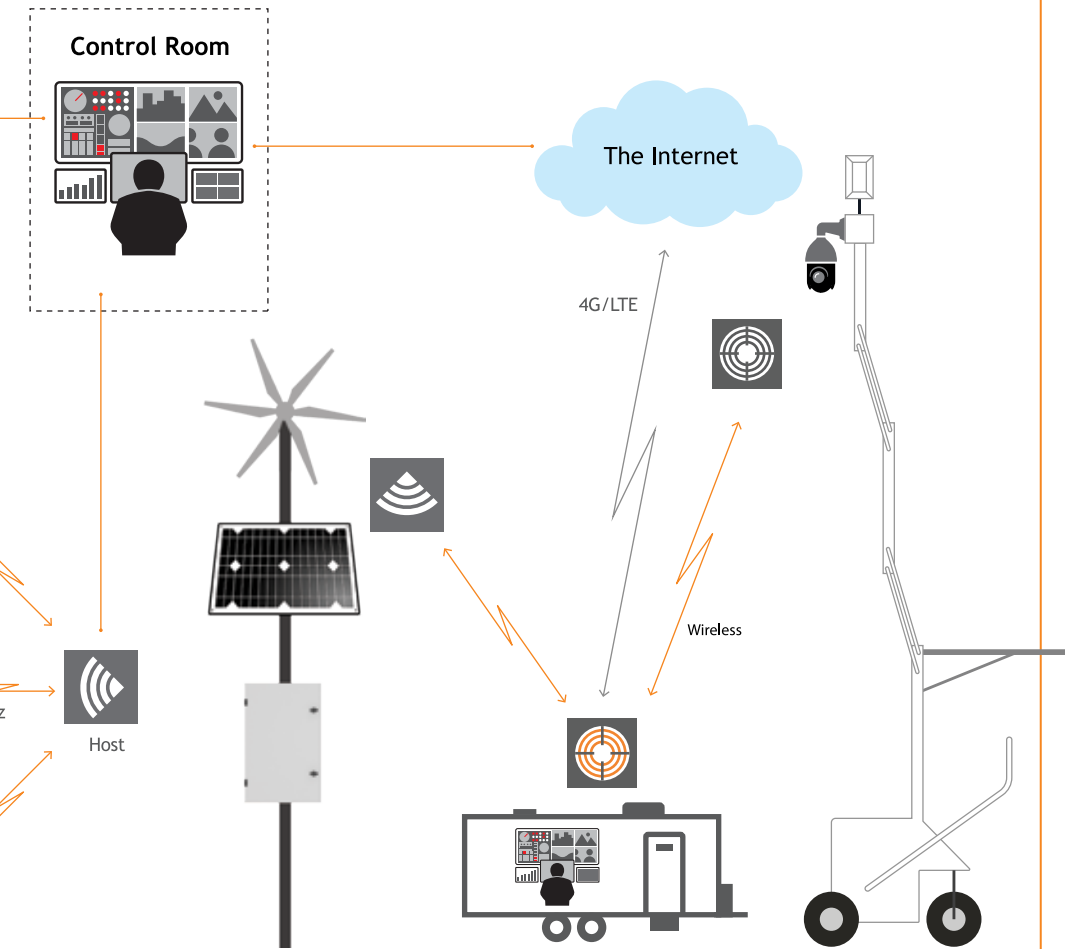

### Ethernet over Coax (EoC) Applications

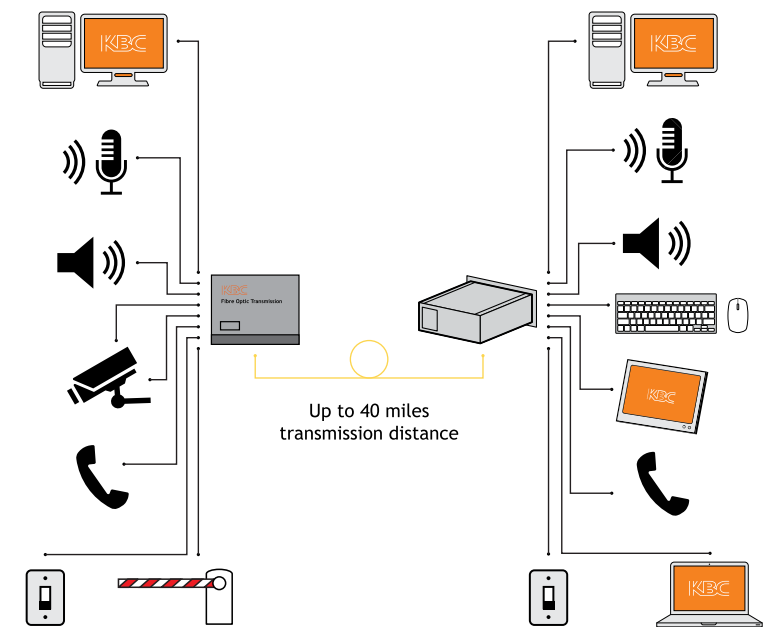
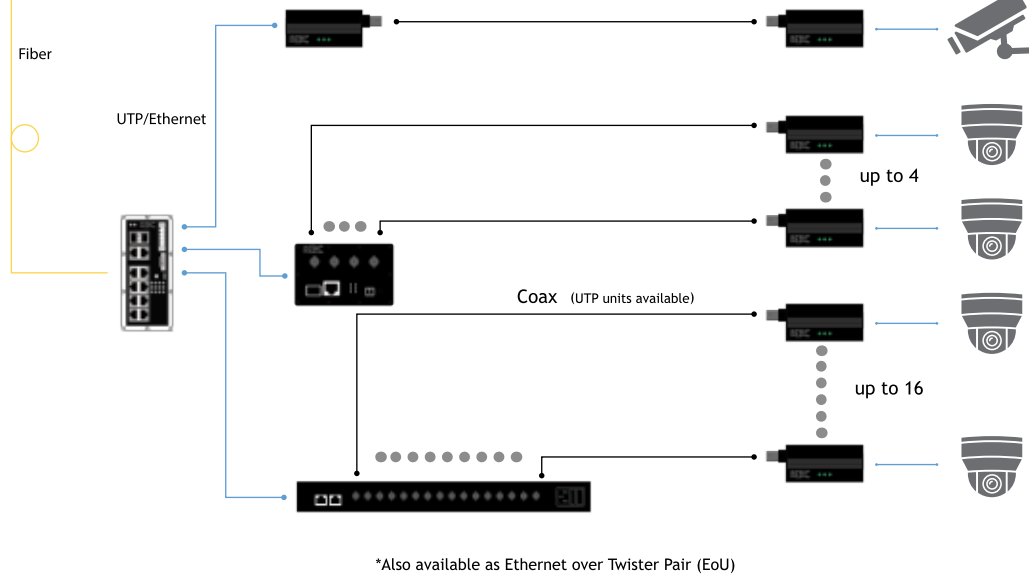

**IP transmission** Ethernet switches, media converters, encoders & decoders, Ethernet extenders, SFPs, and 4G/LTE

**Fiber optic transmission** Video, audio, data, contact closure, Ethernet, telephone, DVI, HD-SDI, 3G-SDI, USB

IP wireless fiber optic remote power



## Integrity

Maintaining close, individual relationships with our customers and partners is our top priority. Everything we do as a company—and as individuals—is handled with complete integrity and respect.

## Service

Superior service and support is a critical component of our business. We believe that successful network and system performance rely on accurate design and correct installation, so our technical and sales teams provide product support throughout the lifecycle of every project. Please contact us for customised pre-sales and technical support.

## Quality

Reliability and high performance are at the core of our design, engineering and manufacturing processes. KBC is proud to offer products and services that go above and beyond recognized international standards.

## More Products

We've included our major product groups in this brochure. For further detail about the complete range, please visit our website: [www.kbcnetworks.com](http://www.kbcnetworks.com), or call your local representative.

## Better Installation

We spend time thinking about our products so you don't have to. KBC products are designed for straightforward set-up; simple analysis and minimal maintenance.

## Greater Performance

Our products are built to perform in commercial and industrial environments. Our industrial ranges feature extended operating temperatures and industrially-hardened casings to withstand temperature extremes and the rigors of industrial and outdoor environments.

### North America Office

KBC Networks  
Brookline 15  
Aliso Viejo, CA 92656  
USA  
Phone: +1 949 297 4930  
Toll Free: +1 888 366 4276  
Fax: +1 949 297 4933  
[sales@kbcnetworks.com](mailto:sales@kbcnetworks.com)

### Mexico Office

KBC Networks  
Luis G. Inclán 2859  
Villa de Cortés  
Mexico City, 03530  
Mexico  
Phone: +52 33 3148 3286  
[latam@kbcnetworks.com](mailto:latam@kbcnetworks.com)

### EMEA Office (Europe, Middle East and Africa)

KBC Networks  
The Nucleus  
Brunel Way, Dartford,  
Kent, DA1 5GA  
United Kingdom  
Phone: +44 (0) 1322 312090  
[emea@kbcnetworks.com](mailto:emea@kbcnetworks.com)

### China Office

81 Nan Xijiang East Road  
Room 919  
Nanjing, Jiangsu 210019  
China  
Phone: +86 25 5882 1656  
[chinasales@kbcnetworks.com](mailto:chinasales@kbcnetworks.com)

[www.kbcnetworks.com](http://www.kbcnetworks.com)

Due to ongoing technological improvements, product specifications are subject to change without notice. KBC Networks is not liable for any errors, omissions or changes of any description of the goods contained herein. This information is for the sole purpose of identifying the products and product ranges, and KBC makes no warranty that the products conform to any description contained herein. Do not rely solely on any representations, statements or assertions concerning these products contained herein.