

**FDVA4-DB1-M1T-WSC
FDVA4-DB1-M1R-WSC
USER MANUAL**

**FDVA4-DB1-M1T-WSC
FDVA4-DB1-M1R-WSC
User Manual**

Table of Contents

1. Overview	3
1.1 Introduction	3
1.2 Technical Specification	3
1.3 Warranty	5
1.4 Instruction of Disassembly.....	6
2. Installation	7
2.1 Package Contents	7
2.2 Transmitter Enclosure	7
2.3 Receiver Enclosure	10
2.4 Caution	12
2.5 Install Application	13
3. Dimensions	14

**FDVA4-DB1-M1T-WSC
FDVA4-DB1-M1R-WSC
USER MANUAL**

1. Overview

1.1 Introduction

The FDVA4-DB1-M1T-WSC/FDVA4-DB1-M1R-WSC series is designed using advanced ASIC and high-speed DSP technologies. This series employs multiplexing and de-multiplexing techniques to transmit and receive 4 channels of video, 1 channel of bi-directional RS232/RS422/2 wires RS485/4 wires RS485 data over a multi-mode optical fiber in all digital signaling with no compression; making it ideal for applications where input signal integrity and quality must be maintained and no loss should be induced. Because this series utilizes all-digital, non-compression technology, it is able to transmit signals without distortion; whereas the analog technology inherently noisy, low quality, long term instability and susceptible to electromagnetically and environmental interference. This series accepts a variety of video inputs, such as analog or digital video recorder, DVD/VCD, digital camera, and CCTV. PAL, NTSC and SECAM standards are supported. It can support standard RS232/RS422/2 wires RS485/4 wires RS485 pan-tilt-zoom control signaling. Plug-and-Play design ensures ease of installation and no electrical or optical adjustment is required. LED indicators are provided for showing operating status.

The FDVA4-DB1-M1T-WSC/FDVA4-DB1-M1R-WSC series is fully assembled using SMT components for stability and reliability.

1.2 Technical Specification

VIDEO	
Number of Channels	4
Signal Level	1.0V _{PP} typical, 1.5V _{PP} max., 75Ω
Differential Gain	< 2%
Differential Phase	< 2°
Signal to Noise Ratio (SNR)	62dB typical
Connector Type	BNC

**FDVA4-DB1-M1T-WSC
FDVA4-DB1-M1R-WSC
USER MANUAL**

DATA	
Number of Channels	1, bi-directional
Interface	RS232/RS422/2 wires RS485/4 wires RS485
RS-232 Data Rate	DC – 115.2kbps
RS-422/485 Data Rate	DC – 250kbps
RS-422/485 Distance	0 – 1200m
RS-422/485 Signaling	Transparent to all RS422/485 signaling; Compatible to 2 wires RS485/ 4 wires RS485.
Connector Type	Terminal

OPTICAL		
Number of Fibers	1	
Wavelength	1310nm (Transmitter)	1550nm (Receiver)
Optical Out Power	≥ -8 dB	≥ -8 dB
Optical Sensitivity	≤ -20 dB	≤ -20 dB
Fiber power budget	≤ 12 dB	≤ 12 dB
Effective Fiber power budget	≤ 12 dB	
Fiber Type	62.5/125μm(MM)	
Connector Type	ST/PC	
Distance	0 ~ 2km	

GENERAL	
Operating Temperature	-40 ~ 70°C / -40 ~ +158°F
Relative Humidity	0 ~ 95% non-condensing
Mean Time Between Failure(MTBF)	> 100,000hrs
Power Supply Adaptors	Input: 100~240VAC, 50/60Hz,0.5A Output: +12VDC, 2A
Enclosure Color	Silver
Dimensions (L×W×H)	223mm×158mm×36mm/8.78"×6.22"×1.42"

**FDVA4-DB1-M1T-WSC
FDVA4-DB1-M1R-WSC
USER MANUAL**

1.3 Warranty

- **Repair**
 - Please contact your local distributors when product is defective. Please apply RA in advance and prepay shipping cost when returning the defective product to us. We will pay the cost for sending it back to you.
 - Please attach a statement clearly describing the problem.
- We will repair defective product under warranty free of charge to our customer.
- 5 years warranty for product only.
- Any unauthorized modification of hardware and software voids the warranty.
- Warranty does not cover mishandling and/or abuse of the product.

Products comply with the following Safety Label for International Fiber Communication Equipment.

NOTE: This equipment has been tested and found to comply with the limits for a Class A digital device, pursuant to Part 15 of the FCC Rules. These limits are designed to provide reasonable protection against harmful interference when the equipment is operated in a commercial environment. This equipment generates, uses and can radiate radio frequency energy and, if not installed and used in accordance with the instruction manual, may cause harmful Interference to radio communications. Operation of this equipment in a residential area is likely to cause harmful interference in which case the user will be required to correct the interference at this own expense.

Warning

This is a class A product. In a domestic environment this product may cause radio interference in which case the user may be required to take adequate measures.

1.4 Instruction of Disassembly

Instruction of Disassembly of KBC Product

(For EU Directive 2002/95/EEC—WEEE)

Tools Required:

- 1) 5 mm flat tip screwdriver
- 2) $\Phi 3$ cross tip screwdriver
- 3) $\Phi 5$ cross tip screwdriver
- 4) Size small snip nose pliers
- 5) 15 mm spanner

Steps for Disassembly:

- 1) Remove tightening screws of box cover (1 or 4-8 screws in general);
- 2) Remove lock nut for BNC with spanner;
- 3) Remove cover plate;
- 4) Remove tightening screws for printed circuit board (PCB);
- 5) In case the assembly has more than one PCB then continue removing the remain tightening screws until none left;
- 6) Use snip nose pliers to loose the nut of flange and then remove optic cable connector (jump wire);
- 7) Snip off power conducting cable and remove power switch /jack/etc.;
- 8) Take out all PCBs;
- 9) Disassembly of product completed.

Notice : When a product reaches the end of it's life—return to KBC

2 Installation

2.1 Package Contents

- One FDVA4-DB1-M1T-WSC Transmitter
- One FDVA4-DB1-M1R-WSC Receiver
- Two power supply adaptors
- Two User Manuals

Please contact dealer or distributor if part is missing or damaged.

2.2 Transmitter Enclosure

Transmitter Top View

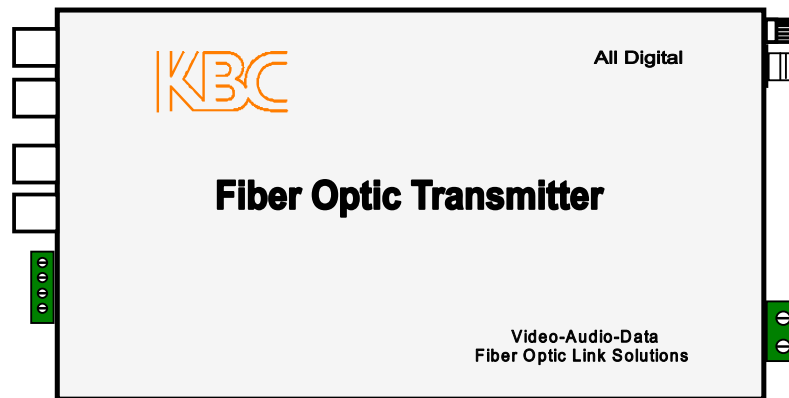

Transmitter Left View

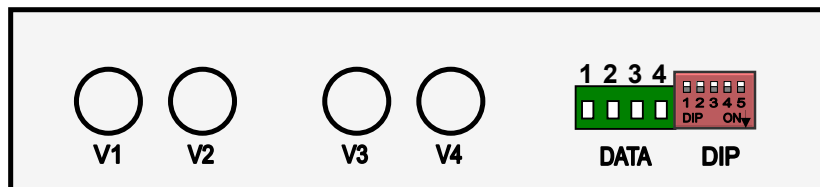

Connectors:

- V1: Channel 1 Video BNC, input
V2: Channel 2 Video BNC, input
V3: Channel 3 Video BNC, input

**FDVA4-DB1-M1T-WSC
FDVA4-DB1-M1R-WSC
USER MANUAL**

V4: Channel 4 Video BNC, input

DATA: RS232/RS422/2 wires RS485/4 wires RS485 compatible
Terminal pins assignment:

Pin Name	1	2	3	4
Data				
RS232	TXD Data transmit signal; input	RXD Data receive signal; output	GND GND of RS232 data	NC (not connected)
RS422	TXD+ Data transmit signal "+", input	TXD- Data transmit signal "-", input	RXD+ Data receive signal "+", output	RXD- Data receive signal "-", output
4 wires RS485	485 TX+ Data transmit signal "+", input	485TX- Data transmit signal "-", input	485RX+ Data receive signal "+", output	485RX- Data receive signal "-", output
2 wires RS485	NC (not connected)	NC (not connected)	485+ Data signal "+"	485- Data signal "-"

DIP Switch setup table:

DIP Switch pin name	RS-232	RS-422	4wire RS-485	2wire RS-485
D1(RS422/4 wires RS485 input terminator 120Ω)	OFF	ON/OFF ②	ON/OFF ②	OFF
D2(2 wires RS485, RS422/4 wires RS485 output terminator 120Ω)	OFF	ON/OFF ②	ON/OFF ②	ON/OFF ②
D3(2 wires RS485/4 wires RS485 output Pull-up/Pull-down resistance)	OFF	OFF	ON/OFF ①	ON/OFF ①
D4(RS232/RS422/2 wires RS485/4 wires RS485 select)	OFF	OFF	ON	ON
D5(RS232/RS422/2 wires RS485/4 wires RS485 select)	ON	OFF	OFF	ON

① The 2 wires RS485/4 wires RS485 output bus pull-up and pull-down resistance usually should be switched on. But if there are several fiber transmitters or receivers, 2 wires RS485/4 wires RS485 output interfaces are connected together, only one of the 2 wires RS485/4 wires RS485 output Pull-up

FDVA4-DB1-M1T-WSC FDVA4-DB1-M1R-WSC USER MANUAL

and Pull-down resistance should be switched on, the others should be switched off.

- ② The terminators can be switched on or off according to the RS485 bus connection. When the fiber transmitter or receiver is placed at the end point of bus, the terminators are usually switched on, but not be must, so the same as RS422.

Transmitter Right View

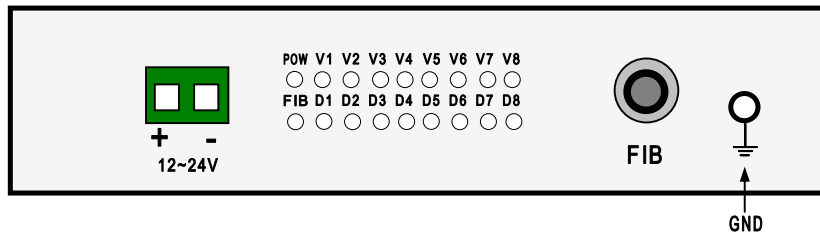

Connectors:

DC or AC Power Supply between 12V and 24V can be used on this product.

- DC:
 - + : +12VDC~+24VDC
 - : Power Supply Ground
- AC:

There is no difference between + / - ; the power supply can be connected into the device directly.

FIB: Fiber Optic ST

GND: Grounded pin

LEDs Definition:

POW:	Power Supply.	On if power input is in OK.
FIB:	Fiber Link.	Off if the link is in OK.
V1:	Channel 1 Video.	On if video input is in OK.
V2:	Channel 2 Video.	On if video input is in OK.
V3:	Channel 3 Video.	On if video input is in OK.
V4:	Channel 4 Video.	On if video input is in OK.
D1:	2 wires RS485 Transmit/ Receive Data.	Flash if there is activity.
	RS232/RS422/ 4 wires RS485 Transmit Data.	Flash if there is activity.
D2:	RS232/RS422/ 4 wires RS485 Receive Data.	Flash if there is activity.

The others are not used.

2.3 Receiver Enclosure

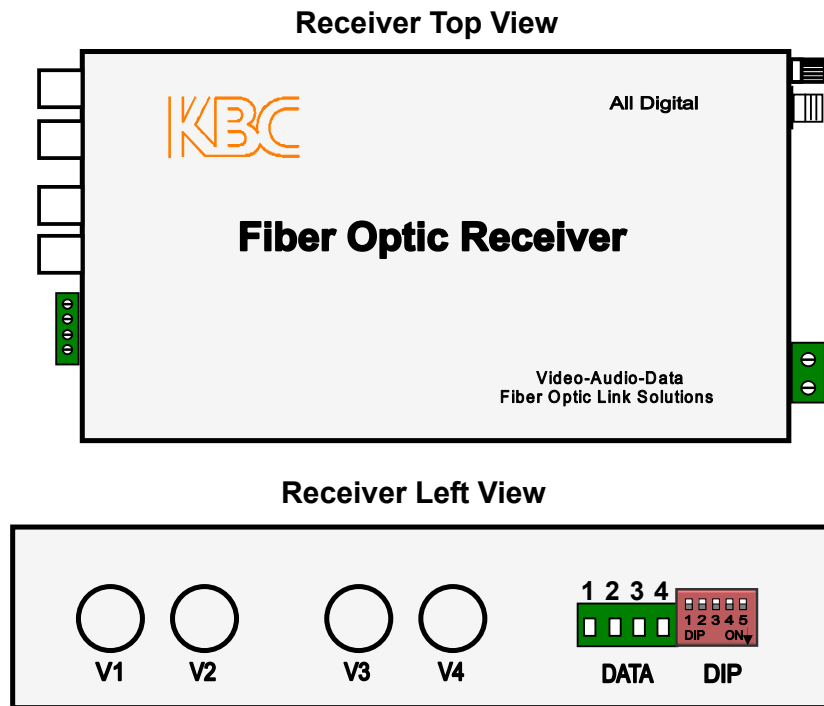

Connectors:

- V1: Channel 1 Video BNC, output
- V2: Channel 2 Video BNC, output
- V3: Channel 3 Video BNC, output
- V4: Channel 4 Video BNC, output

**FDVA4-DB1-M1T-WSC
FDVA4-DB1-M1R-WSC
USER MANUAL**

DATA: RS232/RS422/2 wires RS485/4 wires RS485 compatible
Terminal pins assignment:

Pin Name Data	1	2	3	4
RS232	TXD Data transmit signal; input	RXD Data receive signal; output	GND GND of RS232 data	NC (not connected)
RS422	TXD+ Data transmit signal "+", input	TXD- Data transmit signal "-", input	RXD+ Data receive signal "+", output	RXD- Data receive signal "-", output
4 wires RS485	485 TX+ Data transmit signal "+", input	485TX- Data transmit signal "-", input	485RX+ Data receive signal "+", output	485RX- Data receive signal "-", output
2 wires RS485	NC (not connected)	NC (not connected)	485+ Data signal "+"	485- Data signal "-"

DIP Switch setup table:

DIP Switch pin name	RS-232	RS-422	4wire RS-485	2wire RS-485
D1(RS422/4 wires RS485 input terminator 120Ω)	OFF	ON/OFF ②	ON/OFF ②	OFF
D2(2 wires RS485, RS422/4 wires RS485 output terminator 120Ω)	OFF	ON/OFF ②	ON/OFF ②	ON/OFF ②
D3(2 wires RS485/4 wires RS485 output Pull-up/Pull-down resistance)	OFF	OFF	ON/OFF ①	ON/OFF ①
D4(RS232/RS422/2 wires RS485/4 wires RS485 select)	OFF	OFF	ON	ON
D5(RS232/RS422/2 wires RS485/4 wires RS485 select)	ON	OFF	OFF	ON

FDVA4-DB1-M1T-WSC FDVA4-DB1-M1R-WSC USER MANUAL

- ① The 2 wires RS485/4 wires RS485 output bus pull-up and pull-down resistance usually should be switched on. But if there are several fiber transmitters or receivers, 2 wires RS485/4 wires RS485 output interfaces are connected together, only one of the 2 wires RS485/4 wires RS485 output Pull-up and Pull-down resistance should be switched on, the others should be switched off.
- ② The terminators can be switched on or off according to the RS485 bus connection. When the fiber transmitter or receiver is placed at the end point of bus, the terminators are usually switched on, but not be must, so the same as RS422.

Receiver Right View

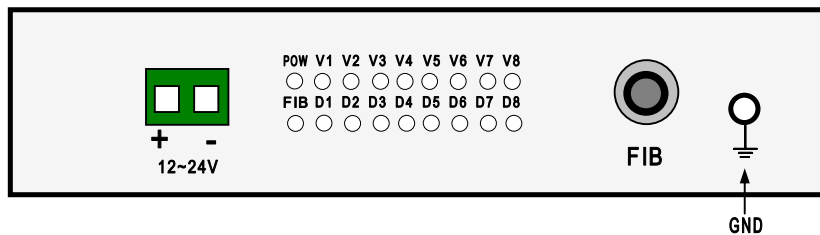

Connectors:

DC or AC Power Supply between 12V and 24V can be used on this product.

- DC:

+: +12VDC~+24VDC

- : Power Supply Ground

- AC:

There is no difference between + / - ; the power supply can be connected into the device directly.

FIB: Fiber Optic ST

GND: Grounded pin

LEDs Definition:

POW:	Power Supply.	On if power input is in OK.
FIB:	Fiber Link.	Off if the link is in OK.
V1:	Channel 1 Video.	On if video output is in OK.
V2:	Channel 2 Video.	On if video output is in OK.

FDVA4-DB1-M1T-WSC FDVA4-DB1-M1R-WSC USER MANUAL

V3:	Channel 3 Video.	On if video output is in OK.
V4:	Channel 4 Video.	On if video output is in OK.
D1:	2 wires RS485 Transmit/ Receive Data.	Flash if there is activity.
	RS232/RS422/ 4 wires RS485 Transmit Data.	Flash if there is activity.
D2:	RS232/RS422/ 4 wires RS485 Receive Data.	Flash if there is activity.

The others are not used.

2.4 Caution

- Switch off all power supply before installation
- Ensure fiber is properly aligned to the receiving connector
- Do NOT stare at the fiber core

2.5 Install Application

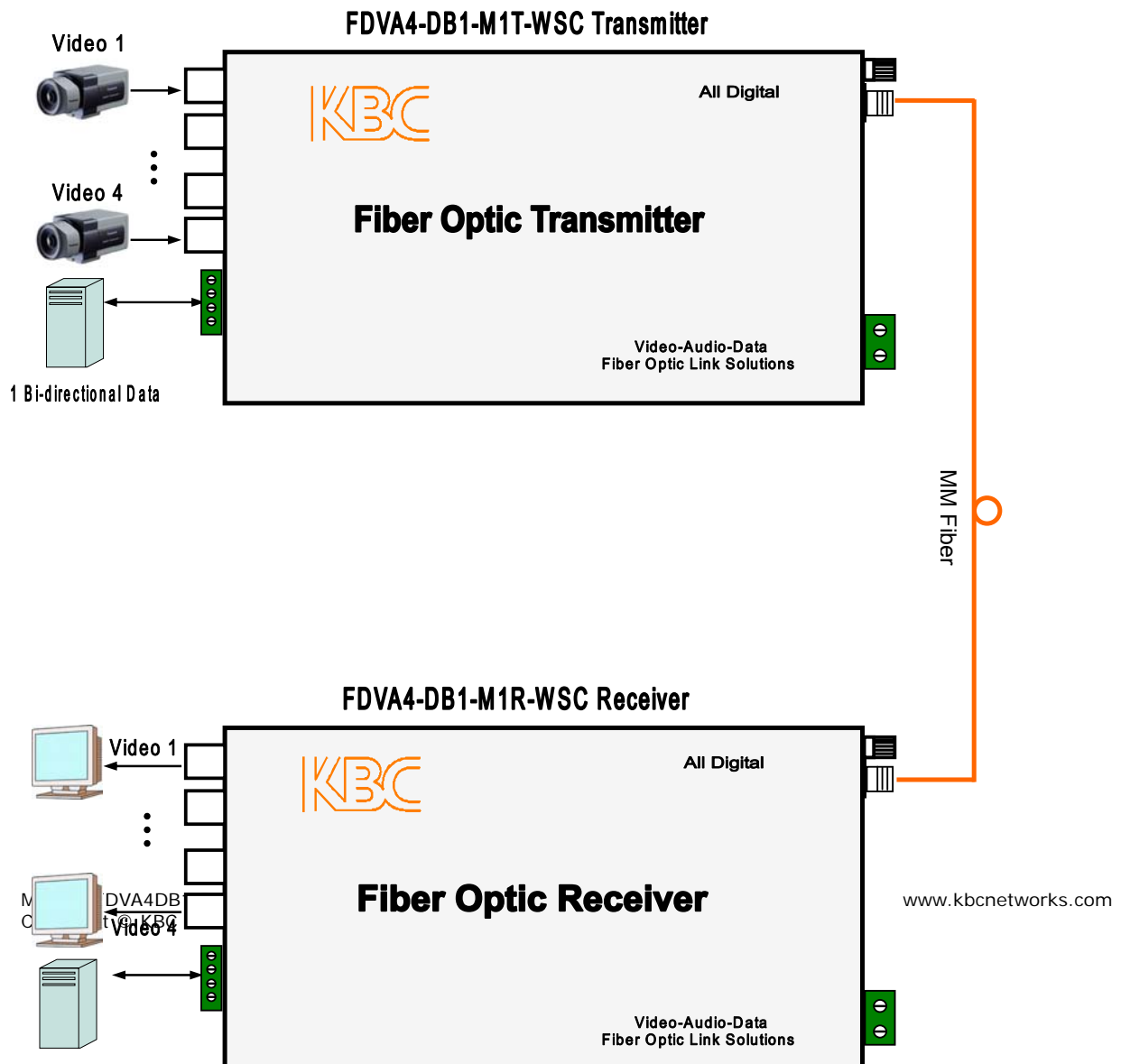

3 Dimensions (mm)

