

**FDVA2-M2T-WSC
FDVA2-M2R-WSC
USER MANUAL**

**FDVA2-M2T-WSC
FDVA2-M2R-WSC
User Manual**

Table of Contents

1. Overview	3
1.1 Introduction	3
1.2 Technical Specification	3
1.3 Warranty	4
1.4 Instruction of Disassembly.....	5
2. Installation	6
2.1 Package Contents	6
2.2 Transmitter Enclosure	6
2.3 Receiver Enclosure	7
2.4 Caution	9
2.5 Install Application	10
3. Dimensions	11

**FDVA2-M2T-WSC
FDVA2-M2R-WSC
USER MANUAL**

1. Overview

1.1 Introduction

The FDVA2-M2T-WSC/FDVA2-M2R-WSC series is designed using advanced ASIC and high-speed DSP technologies. This series employs multiplexing and de-multiplexing techniques to transmit and receive 2 channels of video over 2 multi-mode optical fibers in all digital signaling with no compression; making it ideal for applications where input signal integrity and quality must be maintained and no loss should be induced. Because it utilizes all-digital, non-compression technology, it is able to transmit signals without distortion; whereas the analog technology inherently noisy, low quality, long term instability and susceptible to electromagnetically and environmental interference. This series accepts a variety of video inputs, such as analog or digital video recorder, DVD/VCD, digital camera, and CCTV. PAL, NTSC and SECAM standards are supported. Plug-and-Play design ensures ease of installation and no electrical or optical adjustment is required. LED indicators are provided for showing operating status.

This FDVA2-M2T-WSC/FDVA2-M2R-WSC series is fully assembled using SMT components for stability and reliability.

1.2 Technical Specification

VIDEO	
Number of Channels	2
Signal Level	1.0V _{PP} typical, 1.5V _{PP} max.,75Ω
Differential Gain	< 2%
Differential Phase	< 2°
Signal to Noise Ratio (SNR)	62dB typical
Connector Type	BNC

OPTICAL	
Number of Fibers	2
Wavelength	1310nm
Optical Out Power	≥ -12 dB
Optical Sensitivity	≤ -24 dB
Fiber power budget	≤ 12 dB
Fiber Type	62.5/125μm(MM)
Connector Type	ST/PC
Distance	0 ~2km

**FDVA2-M2T-WSC
FDVA2-M2R-WSC
USER MANUAL**

GENERAL	
Operating Temperature	-40 ~ 70°C / -40 ~ +158°F
Relative Humidity	0 ~ 95% non-condensing
Mean Time Between Failure(MTBF)	> 100,000hrs
Power Supply Adaptors	Input: 100~240VAC, 50/60Hz,0.5A Output: +12VDC, 2A
Enclosure Color	Silver
Dimensions (L×W×H)	155mmx115.5mmx36mm / 6.10"x 4.55"x1.42"

1.3 Warranty

- Repair
 - Please contact your local distributors when product is defective. Please apply RA in advance and prepay shipping cost when returning the defective product to us. We will pay the cost for sending it back to you.
 - Please attach a statement clearly describing the problem.
- We will repair defective product under warranty free of charge to our customer.
- 5 years warranty for product only.
- Any unauthorized modification of hardware and software voids the warranty.
- Warranty does not cover mishandling and/or abuse of the product.

Products comply with the following Safety Label for International Fiber Communication Equipment.

NOTE: This equipment has been tested and found to comply with the limits for a Class A digital device, pursuant to Part 15 of the FCC Rules. These limits are designed to provide reasonable protection against harmful interference when the equipment is operated in a commercial environment. This equipment generates, uses and can radiate radio frequency energy and, if not installed and used in accordance with the instruction manual, may cause harmful Interference to radio communications. Operation of this equipment in a residential area is likely to cause harmful interference in which case the user will be required to correct the interference at this own expense.

Warning

This is a class A product. In a domestic environment this product may cause radio interference in which case the user may be required to take adequate measures.

1.4 Instruction of Disassembly

Instruction of Disassembly of KBC Product (For EU Directive 2002/95/EEC WEEE)

Tools Required:

- 1) 5 mm flat tip screwdriver
- 2) $\Phi 3$ cross tip screwdriver
- 3) $\Phi 5$ cross tip screwdriver
- 4) Size small snip nose pliers
- 5) 15 mm spanner

Steps for Disassembly:

- 1) Remove tightening screws of box cover (1 or 4-8 screws in general);
- 2) Remove lock nut for BNC with spanner;
- 3) Remove cover plate;
- 4) Remove tightening screws for printed circuit board (PCB);
- 5) In case the assembly has more than one PCB then continue removing the remain tightening screws until none left;
- 6) Use snip nose pliers to loose the nut of flange and then remove optic cable connector (jump wire);
- 7) Snip off power conducting cable and remove power switch /jack/etc.;
- 8) Take out all PCBs;
- 9) Disassembly of product completed.

Notice : When a product reaches the end of it's life—return to KBC

2 Installation

2.1 Package Contents

- One FDVA2-M2T-WSC Transmitter
- One FDVA2-M2R-WSC Receiver
- Two power supply adaptors
- Two User Manuals

Please contact dealer or distributor if part is missing or damaged.

2.2 Transmitter Enclosure

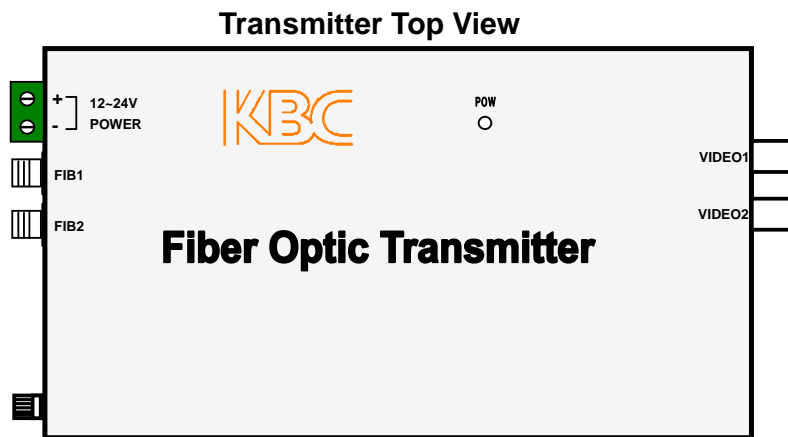

LEDs Definition:

POW: Power Supply. On if power input is in OK.

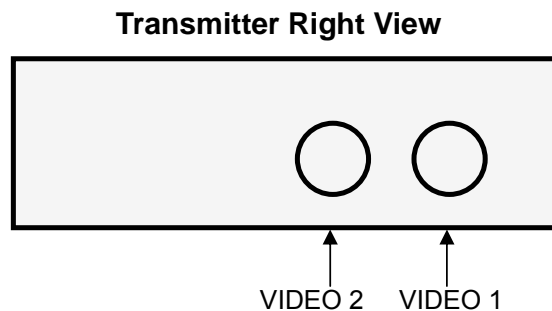

Connectors:

VIDEO 1: Channel 1 Video BNC, input

VIDEO 2: Channel 2 Video BNC, input

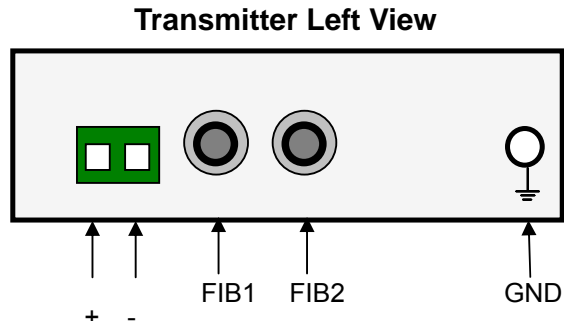

Connectors:

DC or AC Power Supply between 12V and 24V can be used on this product.

- DC:
 - + : +12VDC~+24VDC
 - : Power Supply Ground
- AC:

There is no difference between + / - ; the power supply can be connected into the device directly.

- FIB1: Fiber Optic ST
- FIB2: Fiber Optic ST
- GND: Grounded pin

2.3 Receiver Enclosure

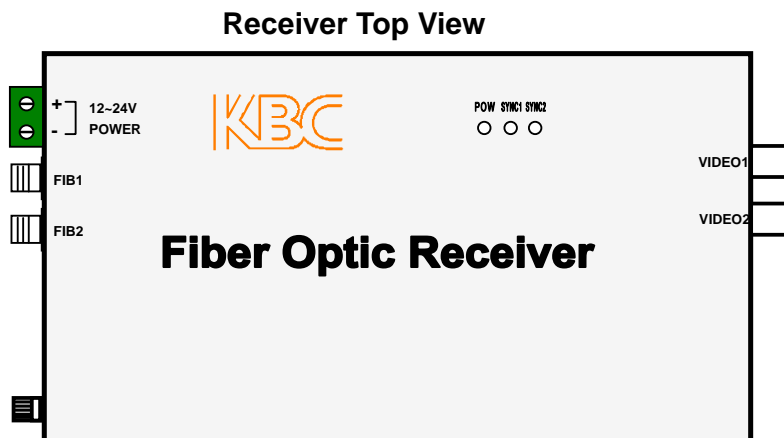

**FDVA2-M2T-WSC
FDVA2-M2R-WSC
USER MANUAL**

LEDs Definition:

POW: Power Supply.	On if power input is in OK.
SYNC1: Fiber Link 1 and Video 1	Flash if the link isn't in OK. Off if the link is in OK but the video isn't in OK.
SYNC2: Fiber Link 2 and Video 2	On if the link and the video are all in OK. Flash if the link isn't in OK. Off if the link is in OK but the video isn't in OK. On if the link and the video are all in OK.

Receiver Right View

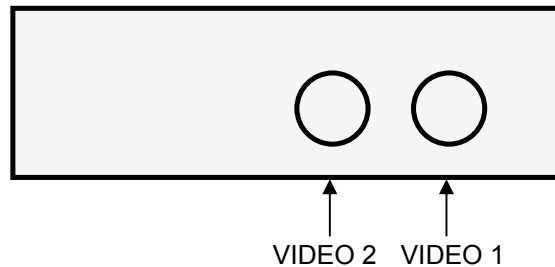

Connectors:

VIDEO 1: Channel 1 Video BNC, output
VIDEO 2: Channel 2 Video BNC, output

Receiver Left View

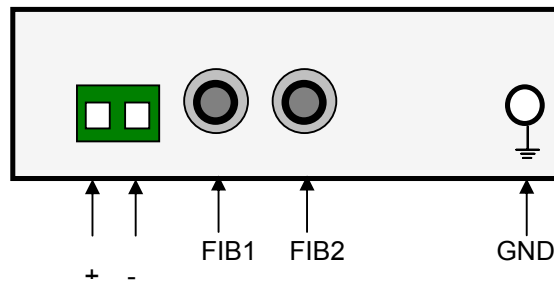

Connectors:

DC or AC Power Supply between 12V and 24V can be used on this product.

- DC:
+: +12VDC~+24VDC

**FDVA2-M2T-WSC
FDVA2-M2R-WSC
USER MANUAL**

- : Power Supply Ground

- AC:

There is no difference between + / - ; the power supply can be connected into the device directly.

FIB1: Fiber Optic ST

FIB2: Fiber Optic ST

GND: Grounded pin

2.4 Caution

- Switch off all power supply before installation
- Ensure fiber is properly aligned to the receiving connector
- Do NOT stare at the fiber core

2.5 Install Application

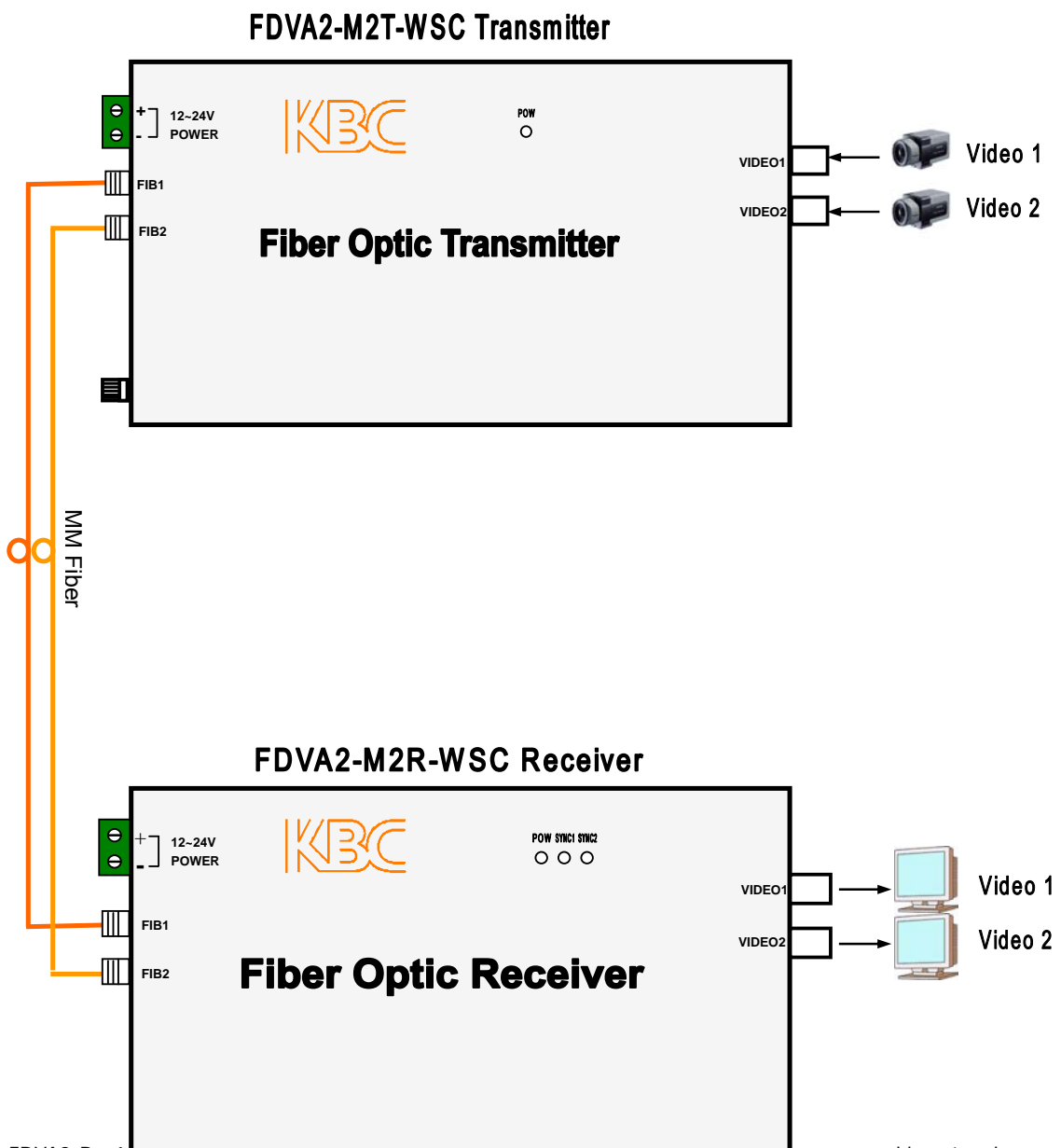



Install Application

3 Dimensions (mm)

