

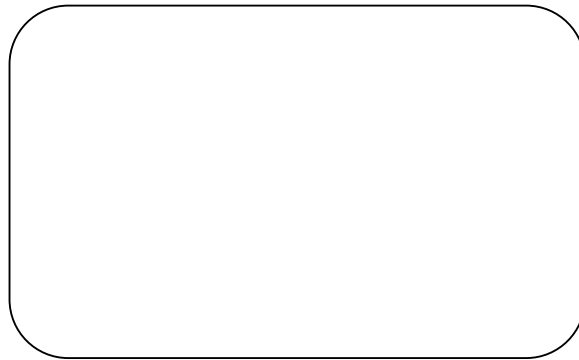

Fiber Optical Transceiver for Up-the-Coax



User Manual

Table of Contents

0. Product Type	1
1. Overview.....	1
1.1 Introduction	1
1.2 Features	1
1.3 Technical Specification	2
2. Package Contents	2
3. Product Enclosure	3
3.1 Transmitter	3
3.2 Receiver	4
4. Caution	6
5. Typical Application.....	6
6. Dimensions	8
7. Warranty	9
8. Instruction of Disassembly	10

0. Product Type



Configuration

Fiber SM MM
 ST/PC SC/PC FC/PC

1. Overview

1.1 Introduction

The KBC FCHA1 series video and data transmission system is designed for full compatibility with 'Up-the-Coax' video/data systems from major manufactures such as Bosch Bi-Linx., and others. This series supports simultaneous 10-bit digitally encoded video and "up the coax" data over one multimode or singlemode fiber. Plug-and-play design ensures ease of installation requiring no electrical or optical adjustments. This series features two optional contact closure circuits that allow two additional devices such as dome tamper switches or alarm inputs to be added. LED indicators are provided to clearly show the operational status of the unit. This series is available in wall mount ,rack mount,or 3U classis card configurations.

1.2 Features

- Transmission of Video and 'Up-the-Coax' Data
- 10-Bit Digitally Encoded Video Transmission
- Exceeds RS-250C Short-Haul Transmission
- 2 channel Bi-Directional Contact Closure circuits optional
- BBV , Bosch ,Pelco or Honeywell selectable
- No Electrical or Optical Adjustments Required
- LED indicators are provided quick diagnosis of all system parameters
- Singlemode & Multimode models.

- Wall mount ,rack mount and 3U classis card configurations
- Special technique is used to extend Bi-Linx transmission distance, the distance depends on optical power.

1.3 Technical Specification

VIDEO	
Signal Level	1.0V _{P-P} typical, 1.5V _{P-P} max.,75Ω
Sampling Resolution	10 bit
Differential Gain	< 1%
Differential Phase	< 1°
Signal to Noise Ratio (SNR)	67dB typical
Connector Type	BNC

CONTACT CLOSURE	
Contact Max. voltage/current	25V/0.8A(DC), 110V/0.4A(AC)
Connector Type	Terminal

OPTICAL	SM		MM	
Wavelength	1310nm	1550nm	1310nm	1550nm
Optical Out Power	≥ -10 dB	≥ -10 dB	≥ -11 dB	≥ -11 dB
Optical Sensitivity	≤ -30 dB	≤ -30 dB	≤ -26 dB	≤ -23 dB
Effective Fiber power budget	≤ 20 dB		≤ 12 dB	
Fiber Type	9/125μm		62.5/125μm	
Distance	0 ~ 30km		0 ~ 4km	

GENERAL	
Operating Temperature	-40 ~ 70°C / -40 ~ +158°F
Relative Humidity	0 ~ 95% non-condensing
Power Supply Adaptor	Input: 100~240VAC, 50/60Hz,0.5A Output: +12VDC, 2A
Mean Time Between Failure(MTBF)	> 100,000hrs
Enclosure Color	Silver
Housing	Wall mount

2. Package Contents

- One Transmitter
- One Receiver
- One User Manual

3. Product Enclosure

3.1 Transmitter

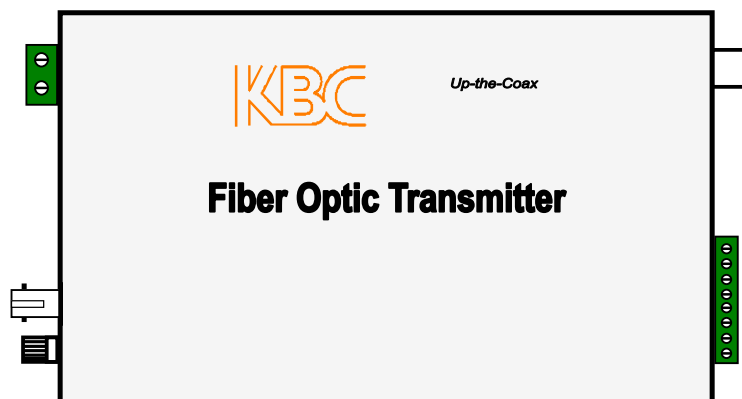

Transmitter Top View

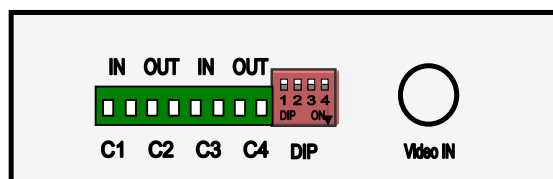

Transmitter Right View

Connectors:

- C1: Channel 1 Contact Closure input.
- C2: Channel 1 Contact Closure output.
- C3: Channel 2 Contact Closure input.
- C4: Channel 2 Contact Closure output.

Terminal pins assignment:

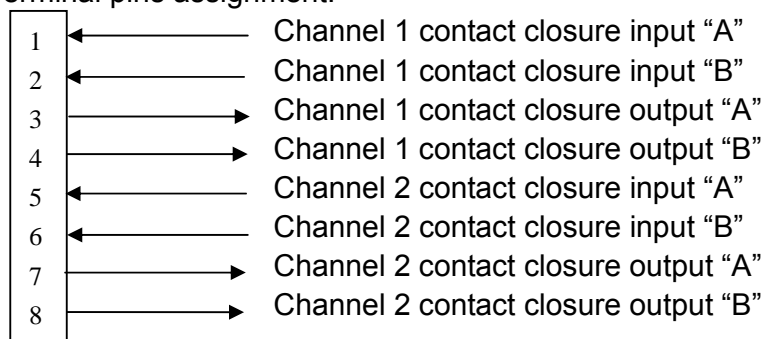

DIP Switch setup table:

DIP Switch pin name	Bosch or Pelco	BBV	Honeywell
D1	OFF	OFF	ON
D2	OFF	ON	ON
D3,D4	Non functional/Reserved		

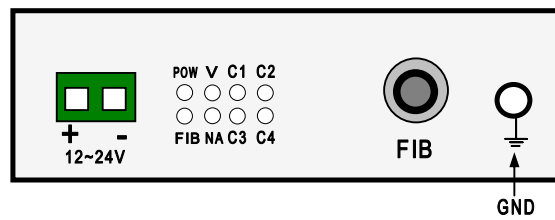

Transmitter Left View

Connectors:

DC or AC Power Supply between 12V and 24V can be used on this product.

- DC:

+ : +12VDC~+24VDC

- : Power Supply Ground

- AC:

There is no difference between + / - ; the power supply can be connected into the device directly.

FIB: Fiber Optic connector.

GND: Ground pin.

LEDs Definition:

POW: Power Supply.

On if power input is in OK.

FIB: Fiber Link.

Off if the link is in OK.

V: Video.

On if video input is in OK.

C1: Channel 1 Contact Closure input.

On if the contact input is closed.

C2: Channel 1 Contact Closure output.

On if the contact output is closed.

C3: Channel 2 Contact Closure input.

On if the contact input is closed.

C4: Channel 2 Contact Closure output.

On if the contact output is closed.

The other is reserved.

3.2 Receiver

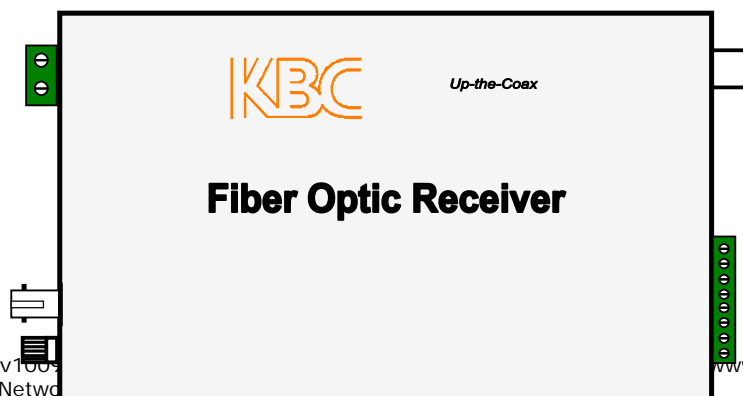

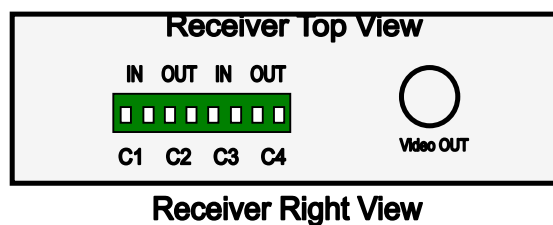
**Connectors:**

- C1: Channel 1 Contact Closure input.
- C2: Channel 1 Contact Closure output.
- C3: Channel 2 Contact Closure input.
- C4: Channel 2 Contact Closure output.

Terminal pins assignment:

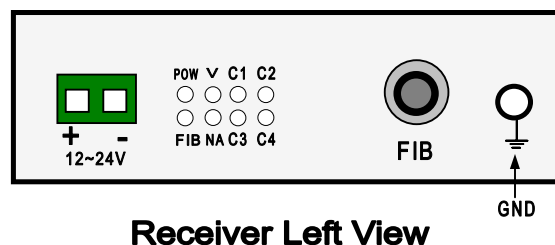
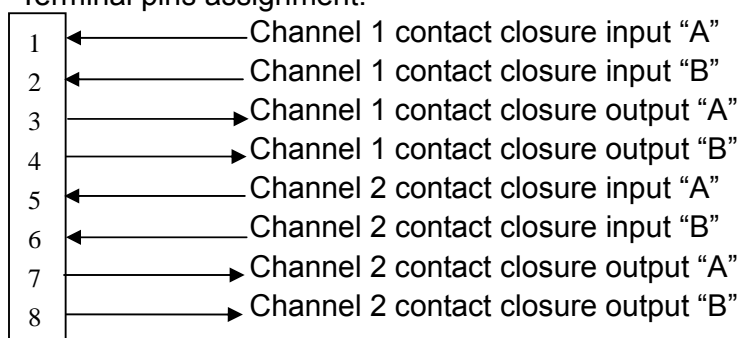
**Connectors:**

DC or AC Power Supply between 12V and 24V can be used on this product.

- DC:
 - + : +12VDC~+24VDC
 - : Power Supply Ground

- AC:

There is no difference between + / - ; the power supply can be connected into the device directly.

FIB: Fiber Optic connector.

GND: Grounded pin.

LEDs Definition:

POW: Power Supply.	On if power input is in OK.
FIB: Fiber Link.	Off if the link is in OK.
V: Video.	On if video output is in OK.
C1: Channel 1 Contact Closure input.	On if the contact input is closed.
C2: Channel 1 Contact Closure output.	On if the contact output is closed.
C3: Channel 2 Contact Closure input.	On if the contact input is closed.
C4: Channel 2 Contact Closure output.	On if the contact output is closed.
The other is reserved.	

4. Caution

- Switch off all power supply before installation.
- Ensure fiber is properly aligned to the Fiber connector.
- Do NOT stare at the fiber core.

5. Typical Application

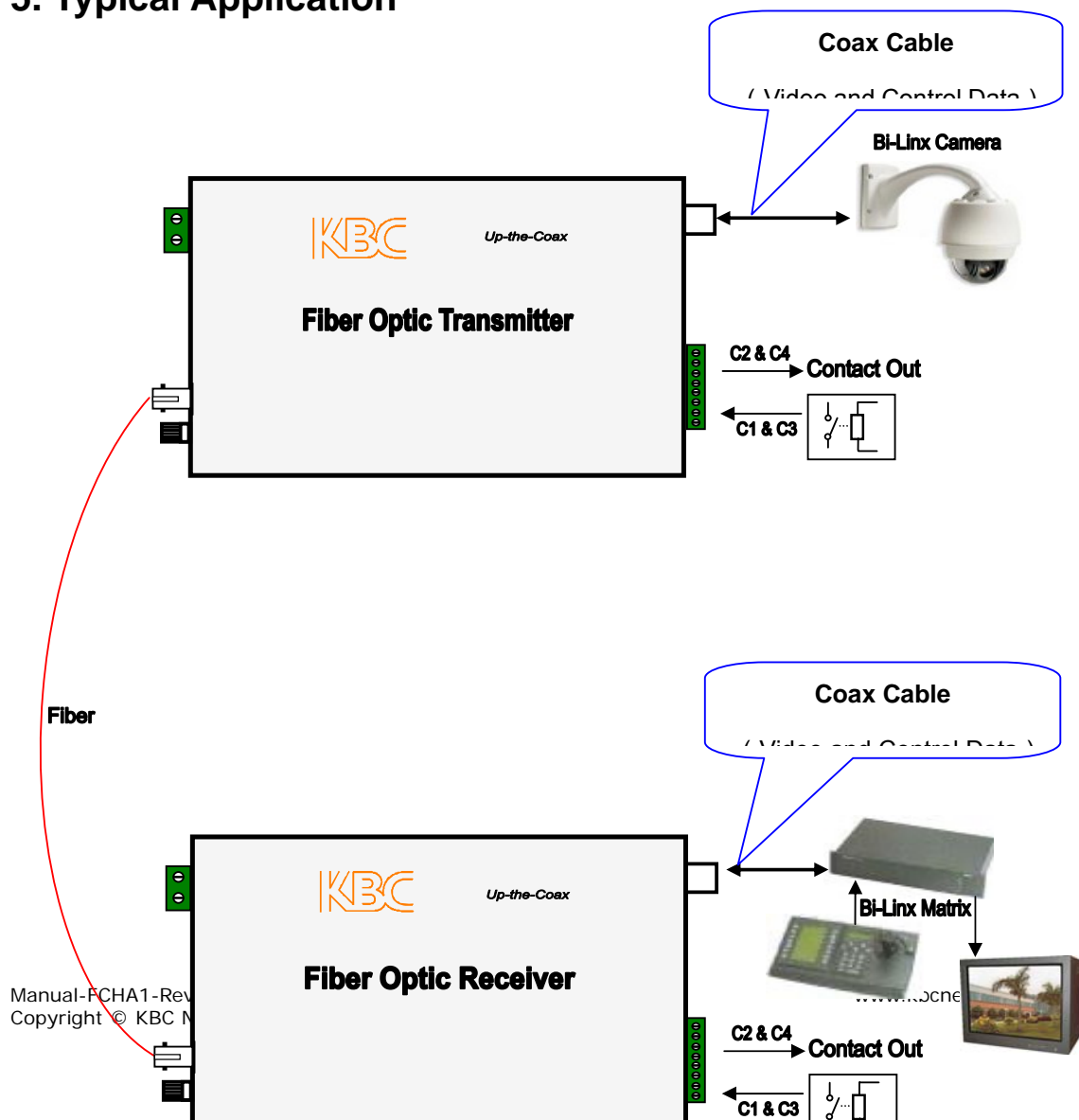

6. Dimensions

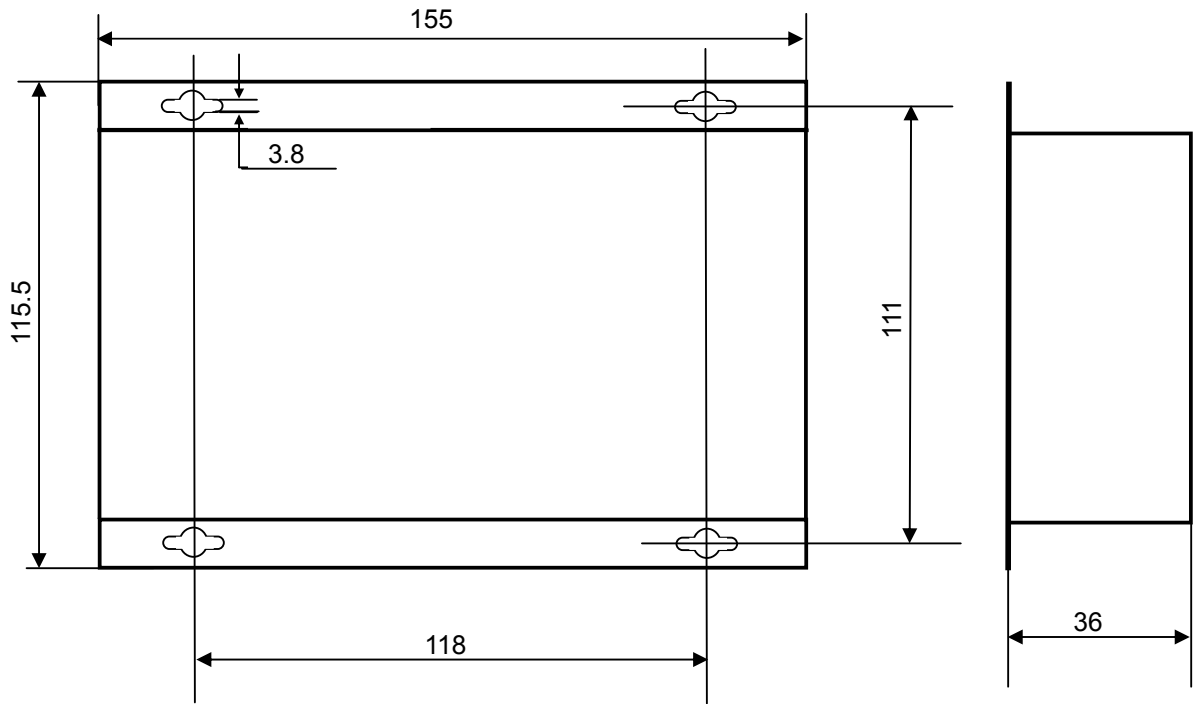

7. Warranty

- 5 years warranty for product only.
- Repair
 - Please contact your local distributors when product is defective. Please apply RA in advance and prepay shipping cost when returning the defective product to us. We will pay the cost for sending it back to you.
 - Please attach a statement clearly describing the problem.
- We will repair defective product under warranty free of charge to our customer.
- Any unauthorized modification of hardware and software voids the warranty.
- Warranty does not cover mishandling and/or abuse of the product.

Products comply with the following Safety Label for International Fiber Communication Equipment.

NOTE: This equipment has been tested and found to comply with the limits for a Class A digital device, pursuant to Part 15 of the FCC Rules. These limits are designed to provide reasonable protection against harmful interference when the equipment is operated in a commercial environment. This equipment generates, uses and can radiate radio frequency energy and, if not installed and used in accordance with the instruction manual, may cause harmful Interference to radio communications. Operation of this equipment in a residential area is likely to cause harmful interference in which case the user will be required to correct the interference at this own expense.

Warning

This is a class A product. In a domestic environment this product may cause radio interference in which case the user may be required to take adequate measures.

8. Instruction of Disassembly

Instruction of Disassembly of KBC Product (For EU Directive 2002/95/EEC—WEEE)

Tools Required:

- 1) 5 mm flat tip screwdriver
- 2) $\Phi 3$ cross tip screwdriver
- 3) $\Phi 5$ cross tip screwdriver
- 4) Size small snip nose pliers
- 5) 15 mm spanner

Steps for Disassembly:

- 1) Remove tightening screws of box cover (1 or 4-8 screws in general);
- 2) Remove lock nut for BNC with spanner;
- 3) Remove cover plate;
- 4) Remove tightening screws for printed circuit board (PCB);
- 5) In case the assembly has more than one PCB then continue removing the remain tightening screws until none left;
- 6) Use snip nose pliers to loose the nut of flange and then remove optic cable connector (jump wire);
- 7) Snip off power conducting cable and remove power switch /jack/etc.;
- 8) Take out all PCBs;
- 9) Disassembly of product completed.

Notice : When a product reaches the end of it's life—return to KBC



Headquarters:

KBC Networks, Ltd.

25691 Atlantic Ocean Drive,

Suite B3

Lake Forest, CA 92630

U.S.A.

Main: 1-949-297-4930

Fax: 1-949-297-4933

KBC Networks Ltd., EMEA

Carlton Suite, Barham Court

Teston, Maidstone

Kent ME18 5BZ

United Kingdom

Office: +44(0)1622618787

Fax: +44(0)2071008147

Email: info@kbcnetworks.com

Web: www.kbcnetworks.com