

## Quick Start Guide EERN1-LN1-X-MX-B

### EoU Transmitter & Receiver - 1 UTP Connector and 1 RJ45

## Introduction

The KBC EERN1-LN1-X-MX-B is a fully ruggedized Ethernet over UTP transmitter and receiver set. This product provides connectivity for one 10/100Mbps IEEE standard electrical copper port over UTP cable. Varying data rates are supported depending on cable distance and quality. The plug-and-play design ensures ease of installation with no electrical adjustment needed. LED indicators are provided to show the operational status of the unit.

The size of the product is suited for fitting inside camera housings and where space is limited.

## Features

- 1 UTP port and 1\*10/100M Ethernet port
- UTP data rate >30Mbps (600m)
- 12-24VDC power input
- Complete protection design, including surge and lightning protection

## Downloads

Full specifications, features and additional information can be found on the KBC website: [www.kbcnetworks.com](http://www.kbcnetworks.com).

## General

Check the product upon receipt for any visible damage which may have occurred during shipping.

## Physical Deployment

This equipment must be installed and operated in accordance with instructions found in this document. Failure to comply with these instructions will invalidate the warranty.

## Application

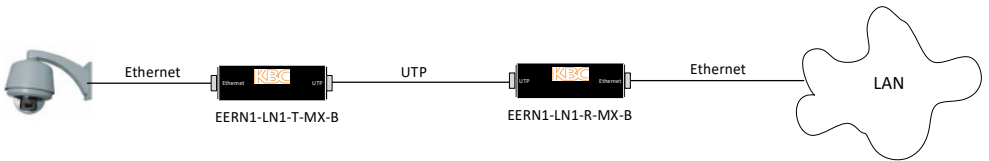

## Panel Views

### Top View (Transmitter)

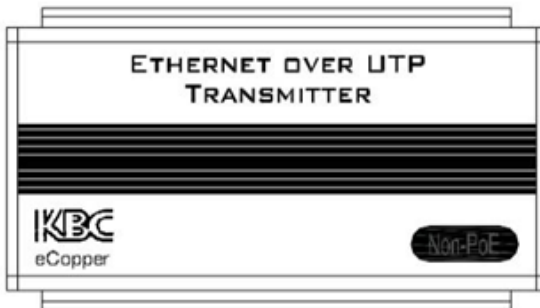

## Top View (Receiver)

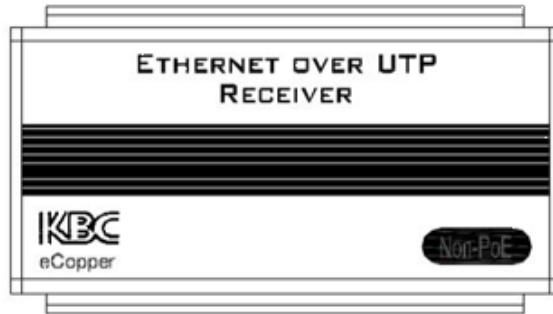

## Side View

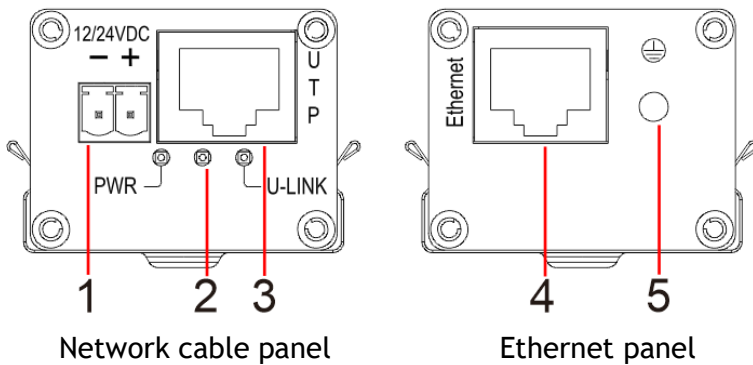

- 1 - Power input; 2 - LED indicators; 3 - Network cable connector;  
4 - Ethernet RJ45 port; 5 - Grounding terminal.

LED	Color	Status	Description
PWR	Orange	On	Power supply is normal.
U-LINK	Green	On	EoU connection is normal.
Ethernet Link/Act	Orange	On/Blink	On: Ethernet link is normal. Blink: Data is active.

## Ethernet RJ45 Definition

Pin	Signal
1	TD+
2	TD-
3	RD+
4	N/A
5	N/A
6	RD-
7	N/A
8	N/A

### Notes:

★ Please use straight-through cable rather than cross-over cable.

8 wires transmission: all 8 wires need to be connected.

4 wires transmission: any 2 wires of PIN 1,2,4 and 5 as "+", any 2 wires of PIN 3,6,7 and 8 as "-".

2 wires transmission: any 1 wire of PIN 1,2,4 and 5 as "+", any 1 wire of PIN 3,6,7 and 8 as "-".

# Dimensions (Unit = mm)

Equipment:

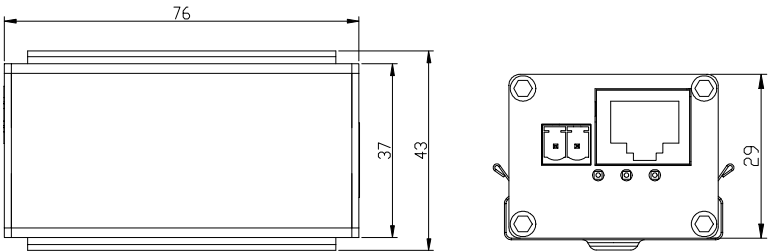

Installation Accessories:

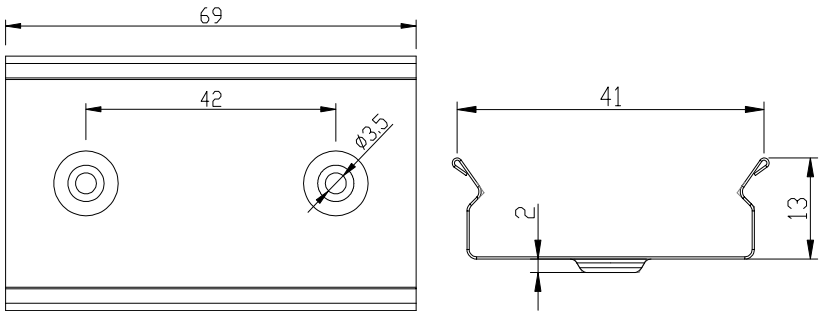

## Specifications

Item		Description
Power	Power Input	12/24VDC
	Consumption	<2W
Cable	Transmission Medium	Cat5e/6 cable
	Operating Frequency	2M-28M
	Modulation	Wavelet-OFDM
	Transmission Rate	210Mbps (Max.)
	Power Negotiation Cycle	1S
	Overcurrent	720mA
	Overcurrent Protection Time	<2mS
	Transmission Distance	*600m
Ethernet Port	Transmission Medium	Cat5e/6
	Standard	IEEE802.3, IEEE802.3U
	Ethernet Delay	<1mS
Protection	ESD	IEC61000-4-2
	Anti-Thunder Protection	IEC61000-4-5 level 3
Operation Environment	Operating Temperature	-20°C~+70°C
	Storage Temperature	-40°C~+85°C
	Humidity (Non-Condensing)	0-90%
Mechanical	Dimension (L×W×H)	76mm*37mm*29mm
	Material	Aluminum
	Color	Black
	Weight	0.2Kg

\*Transmission distance depends on signal source and cable quality.

## Installation Instructions

Please check the following items before installation. If any items are missing, please contact the dealer.

- EoU transmitter/receiver ----- x1
- Wall mounting clamp ----- x1
- QSG/User manual----- x1
- Screws----- x2

Please follow the installation steps below:

- 1) Attach the clamp to the wall using the 2X10mm screws.

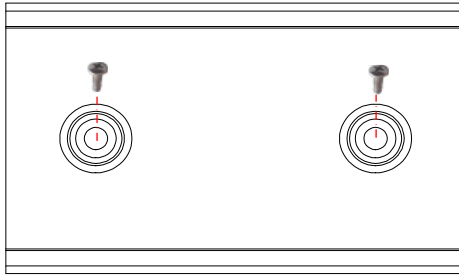

- 2) Press the transmitter/receiver into the clamp.

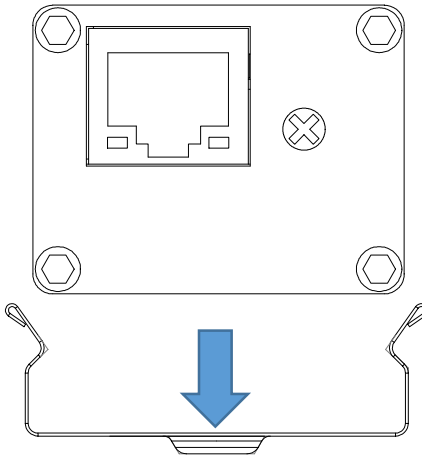

- 3) Use a network cable to connect the Ethernet port to the powered device (T) or Ethernet switch (R). Connect the UTP port of the transmitter to the receiver and use a grounding wire to connect the grounding terminal.

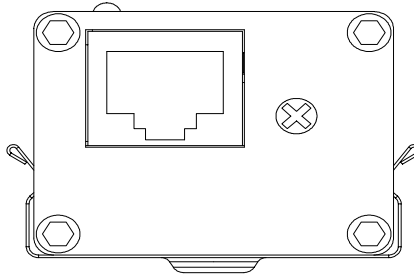

- 4) Check that the installation is correct and power on the device to be sure it is operating normally.

## Troubleshooting

Please refer to the following information if the device does not work:

- Confirm the installation is according to the factory installation requirements.
- Confirm the RJ45 cable order follows the EIA/TIA568A or 568B industry standards.
- The maximum transmission distance depends on the signal source and cable quality. Please do not exceed the maximum transmission distance.
- Please replace the failed device with a known working unit to determine if you have a damaged or faulty unit.
- If the problem persists, please contact your nearest KBC office or dealer.

## Need Help?

Please visit our website [www.kbcnetworks.com](http://www.kbcnetworks.com), or contact your nearest KBC office or dealer.